



GOA SHIPYARD LIMITED

(MINISTRY OF DEFENCE)
Vasco-Da-Gama, Goa 403 802

The following details are furnished in compliance with Chapter-II, Section- 4 (1) (b) Of the Right to Information Act 2005.

4 (1) (b) (i) THE PARTICULARS OF ITS ORGANIZATION FUNCTION AND DUTIES

VISION:

To be a contemporary organization in Ship Design, Construction, Ship Repairs & General Engineering Solution.

MISSION:

To be a world class Shipbuilding Yard to meet maritime needs of indigenous & export market by designing, building, repairing & delivering products & Engineering Services on time at competitive price.

[GSL Core Values](#)

[GSL Corporate Objectives](#)

[GSL code of business conduct & Ethics](#)

Business of the Company:

GSL has been established to carry out the objectives specified in the Memorandum & Articles of Association of the Company as amended from time to time.

The main activities of GSL are –

1. Shipbuilding.
2. Ship Repair.
3. General Engineering Services.

ORGANIZATION (GENESIS, INCEPTION, FORMATION OF DEPARTMENTS)

- a) Date of Incorporation:29.09.1967
- b) Administrative Ministry: Ministry of Defence, Government of India
- c) Details: Goa Shipyard Limited is a Central Public Sector Undertaking with Mini Ratna Schedule-B status, engaged in Ship Building, Ship Repairs & General Engineering services. The affairs of the company are governed by Board of Directors nominated by the Hon'ble President of India.

The company owns and operates the following industrial units/Liaison offices

Unit	Address	Contact Numbers
GSL Main Unit	Vaddem, Vasco-Da-GamaGoa 403802	91-832-2512152 (5 LINES) / 2513954 / 2512359/2514467 Fax: 91-832-2513260/2513943/ /2512148
Sancole (Unit II, III, IV, V)	Industrial Estate, Zuari Nagar, Vasco Da-Gama, Goa 403802	91-832-2555962
Karwar Office	Siddhi Apartment, Ground Floor, Behind Main Karwar Bus Stand	0832-2295129
LIASION OFFICES		
Mumbai	C/o. Mazagon Dock Shipbuilders Ltd., Dockyard Road, Mazagon, Mumbai - 400010	91-22-23762000, 91-22-23763000, 91-22-23764000
Delhi	Goa Shipyard Limited, H Block Annexe, Defence Headquarters, Krishna Menon Marg, New Delhi-110011	91-11-23011248 91-11-23011249 Fax: 91-11-23015681

UPDATED ORGANOGRAM OF GOA SHIPYARD LIMITED

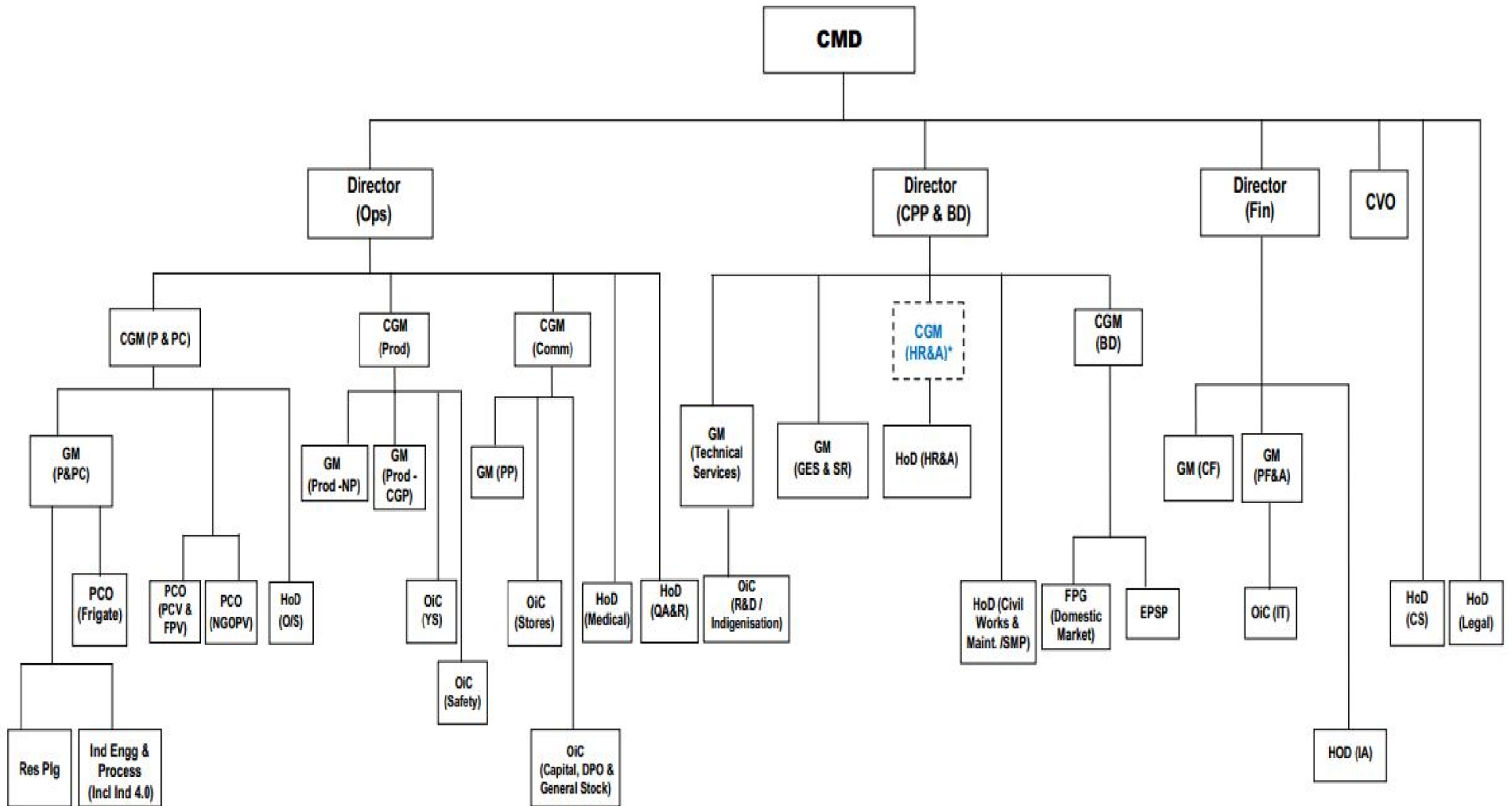

* The position will be in force on assumption of the charge.

Handwritten signature/initials

Abbreviations

CMD	Chairman & Managing Director
Director (CPP&BD)	Director (Corporate Planning, Projects & Business Development)
Director (Fin)	Director (Finance)
Director (Ops)	Director (Operations)
CVO	Chief Vigilance Officer
CGM (P&PC)	Chief General Manager (Planning & Project Control)
CGM (Prod)	Chief General Manager (Production)
CGM (Comm)	Chief General Manager (Commercial)
CGM (HR&A)	Chief General Manager (Human Resources & Administration)
CGM (BD)	Chief General Manager (Business Development)
GM (P&PC)	General Manager (Planning & Project Control)
GM (Prod - NP)	General Manager (Production - Navy Projects)
GM (Prod - CGP)	General Manager (Production - Coast Guard Projects)
GM (PP)	General Manager (Projects Procurement)
GM (TS)	General Manager (Technical Services)
GM (GES & SR)	General Manager (General Engineering Services & Ship Repairs)
GM (CF)	General Manager (Corporate Finance)
GM (PF&A)	General Manager (Project Finance & Accounting)
HoD (HR&A)	Head of Department (Human Resources & Administration)
HoD (O/S)	Head of Department (Outsourcing)
HoD (Medical)	Head of Department (Medical)
HoD (QA&R)	Head of Department (Quality Assurance & Reliability)
HoD (Civil Works & Maint / SMP)	Head of Department (Civil Works & Maintenance / Shipyard Modernisation Project)
HoD (IA)	Head of Department (Internal Audit)
HoD (CS)	Head of Department (Company Secretary)
HoD (Legal)	Head of Department (Legal)
OIC (YS)	Officer-In-Charge (Yard Services)
PCO (Frigate)	Project Coordinating Officer (Frigates)
PCO (PCV & FPV)	Project Coordinating Officer (Pollution Control Vessel & Fast Patrol Vessel)
PCO (NGOPV)	Project Coordinating Officer (Next Generation Offshore Patrol Vessel)
OIC (Stores)	Officer-In-Charge (Stores)
OIC (R&D / Indigenisation)	Officer-In-Charge (R&D / Indigenisation)
OIC (IT)	Officer-In-Charge (Information Technology)
OIC (Safety)	Officer-In-Charge (Safety)
OIC (Capital, DPO & General Stock)	Officer-In-Charge (Capital, Direct Purchase Order & General Stock)
Res Plg	Resource Planning
Ind Engg & Process (Incl Ind 4.0)	Industrial Engineering & Process (Including Industry 4.0)
FPG (Domestic Market)	Forward Project Group (Domestic Market)
EPSP	Export Promotion & Strategic Projects

ORGANISATION CHART OF INDIVIDUAL DEPARTMENTS

These departments have been formed since inception of the company and their functioning is being suitably modified based on the needs of the company.

THE EMERGING FUTURE AT GOA SHIPYARD LIMITED

As India took its first steps as a political entity in 1947, the policy makers recognized that it would be in the country's best interests to cultivate indigenous warship building as a strategic capability. In 1961, after Goa's liberation, the potential of a small shipyard called "Estaleiros Navais de Goa" to contribute towards this national aspiration was recognized. The Yard, later renamed Goa Shipyard Limited, was consciously shaped, developed and upgraded to become one of the country's premier defence shipbuilding hubs on the west coast.

Over the years, Goa Shipyard Ltd. gradually developed to meet the growing shipbuilding needs of the country's naval defence sector, in the process going on to design and build a wide range of vessels for the defence as well as the commercial sectors.

As one of the few Indian shipyards equipped with an in-house design capability, GSL carries out its own Research & Development, in the process developing an in-house product range that efficiently meets the specific requirements of clients in the defence as well as commercial sectors in the fields of design, construction, repair and modernization of vessels. Most new shipbuilding projects at GSL are based on our own in-house design – the result of intensive R&D activity carried out over the years. Currently, the Company is developing a range of Patrol Vessels from 29 m to 110m.

While making consistent progress in its core competency of shipbuilding, the Yard has also proactively moved to exploit market opportunities by successfully diversifying into a related product range. It has designed and constructed Training Simulators for the Indian Navy and Oil & Natural Gas Corporation. A series of Interceptor boats have been built for the Ministry of Home Affairs and are used by the Coastal State Police on the west coast. The Damage Control Simulator built by Goa Shipyard for the Indian Navy, incidentally, is the only one of its kind in Asia and one of the very few existing worldwide. A Survival at Sea Training Facility has been designed and constructed by Goa Shipyard for ONGC for training of their personnel in meeting with real life emergencies that may occur on oil platforms. GSL has executed India's first Shore Based Training Facility for carrier borne aircraft in association with the Aeronautical Development Agency of Bengaluru at INS Hansa, Goa. The facility will be used to train pilots for the MiG-29K and the indigenous LCA-Navy.

In keeping pace with today's dynamic times, Goa Shipyard Ltd. has launched upon a massive modernization programme aimed at creating new facilities and infrastructure even as existing facilities are augmented, to undertake the anticipated work load of ship construction in the years to come, including series construction of high technology ships for the Indian Navy and Coast Guard.

The modernisation plan is a result of a vision of the Ministry of Defence Production and GSL, to have a contemporary Shipyard. The modernization project implemented in four phases will include a new integrated steel fabrication facility using modular construction technique and modern workshops. It will have dedicated building berths with shiplift and transfer system, dry repair berths, enhanced material handling and new crane facilities. There will be new material stores, a GRP complex for construction of MCMVs, fitting out jetties for ship outfitting, MCMV & repair ships and revamping of electrical and mechanical services and utilities. Rationalisation of resource utilization, introduction of state-of-the-art multipliers and business methods in all areas of shipbuilding, ship repair and life time support are also on the agenda. This remodeling will enable us to meet the qualitative and quantitative objectives of building and delivering quality ships at competitive cost with shorter construction periods and delivery times as well as increased capacity and product mix.

The blueprint of the new construction facilities is based on a “product centre concept”, where the ship construction process is streamlined through four distinct multi-functional production complexes that are easily manageable through localization of the mix of trade skills and the equipment required to complete the ship production process. This will minimise the movement of the workforce in various locations around the shipyard, and bring improved efficiencies of equipment and tooling, creating a highly efficient working environment, reduction in capital investment and reduction in operating costs by minimizing materials handling time.

Phases 1 and 2 of the Modernisation Project was commissioned on May 21st, 2011. This part of the Modernisation Project, has enhanced the Yard's infrastructure with a system capable of docking 120 M vessels upto 6000 T and a Ship Transfer Area of around 13600 sq. mts. GSL can now count itself as India's first Defence Shipyard to be equipped with a modern Ship lift facility for launching and docking of ships. The commissioning of the ship lift has given impetus to repair activities.

The Modernisation Project will give GSL the ability to build vessels to customer's requirements in shorter time frames than at present. Once fully complete, it will result in substantial augmentation of the Shipyard's capacity to fabricate steel, aluminum and GRP hull vessels to nearly three times its present capacity, whilst also leading to a quantum increase in the ship repair segment. This is a part of enhancing India's strategic ability to design and build its “own ships”. Goa Shipyard Limited (GSL), is a leading ISO 9001-2015 certified shipyard on the West Coast of India, functioning under the administrative control of Ministry of

Defence, Govt. of India.

GSL is strategically located on the banks of river Zuari in Goa, a major international tourist destination well connected by its international airport and major port enroute all important shipping lines. Beginning as a small barge building yard, GSL has garnered reputation as one of the most sophisticated ship builders in the Country. For over four decades, GSL has designed, built and commissioned a wide range of sophisticated vessels for varied applications in the defence and commercial sectors with special expertise in building modern patrol vessels of Steel and Aluminum hull structure.

GSL's inherent strengths are

- An ISO 9001 Certified Company In-house design capability.
- World class CAD/CAM facility with Tribon platform.
- ERP enabled management integrated with design and planning application which enables for effective database management, project monitoring and control.
- Shift Lift facility of 6000 Tonnes and Repair berths.
- Modern steel preparation shop with CNC plate cutting machines, automatic shot blasting equipment & CNC pipe bending machine.
- Modern Electronic Workshop.
- Ship Repair and General Engineering Services. Setting up of Simulated Training facilities.
- A workforce of over 1500 skilled personnel including 250 Officers.

Services Offered

GSL offers a wide spectrum of services to its valued customers which include:

- Designing and building variety of vessels and simulating training facility. Repair and modernization of vessels.
- Supply of Stern Gear.

4 (1) (b) (ii) THE POWERS AND DUTIES OF ITS OFFICERS AND EMPLOYEES

Goa Shipyard Limited is a Board managed Company headed by Chairman & Managing Director, appointed by the President of India. The Board oversees the Company's strategic direction, review and monitors corporate performance, and safeguards the interests of shareholders. The Board has delegated powers of management to CMD. CMD has sub-delegated the required powers to Functional Directors, Chief General Managers, General Managers, Heads of Departments (HODs) and Officers to effectively carry out the responsibilities of their respective departments.

FUNCTIONS AND DUTIES:

The various functions and duties being performed in GSL and the department heads responsible for smooth functioning of their respective departments are listed below:

Department	Deptt. / Section Head
Planning	CGM(P&PC)
Commercial Dept	GM(PP)
Quality Assurance	HOD(QA&R)
Production Department	GM (Prod)
Forward Project Group	Head(FPG)
General Engineering Service	GM(GES)
Tech. Services	GM(TS)
Outsourcing Cell	HOD(OS)
Ship Repairs	GM (SR)
Shipyard Modernization Project Department	HOD (SMP)
Finance Department	GM(PROJECT FINANCE & ACCOUNTING)
Finance Department	GM(CORPORATE FINANCE)
HR and Admin. Dept	HOD(HR&A)
Security & Admin. Section	AGM(Admin)
Information Technology	AGM(ERP-MCMV)
Civil Section	AGM(Civil)
Health, Safety & Environment	AGM(Med)
Vigilance	CVO
Legal Department	AGM(L)
Secretarial Section	AGM(CS)
Yard Services	AGM (Prod.)
Design Engineering Section	AGM(D/E)
Design Electrical Section	AGM(D/L)

गोवा शिपयार्ड लिमिटेड /GOA SHIPYARD LIMITED

R&D/INDIGENISATION	AGM(Chief Indigenisation off)
Block Assembly Workshop (BAW)	AGM(BAW)
Hull Outfit	AGM(OF/H)
Stores Dept	AGM(Stores)
Electrical Outfit	AGM(OF/L)
Hull Construction	DGM(HC)
SPS	DGM(SPS)
Safety Cell	DGM(Safety)
Export Promotion & Strategic Projects Group	DGM(EPSP)
Plant Maintenance	DGM (Prod.)
Fitting Out Engg.	DGM(E&P)
Internal Audit	DGM(IA)
Official Language	SM(OL)
Public Relations Section	SM(PR)
Naval Project & Outsourcing Section	M(D/H)
Pipe Shop	M(P/S)
Ship Lift/Shipwright	DM(SW)
Paint Shop	DM (Pord)
Power House E&W	DM(PH/E)
Carpentry	JM (Prod)

Copy of Delegation of Powers is available with respective Sections/Departments which are referred for performing day to work associated with their respective sections

4 (1) (b) (ii) THE PROCEDURE FOLLOWED IN THE DECISION MAKING PROCESS, INCLUDING CHANNELS OF SUPERVISION AND ACCOUNTABILITY

The decisions making process in the company involves the following channel:

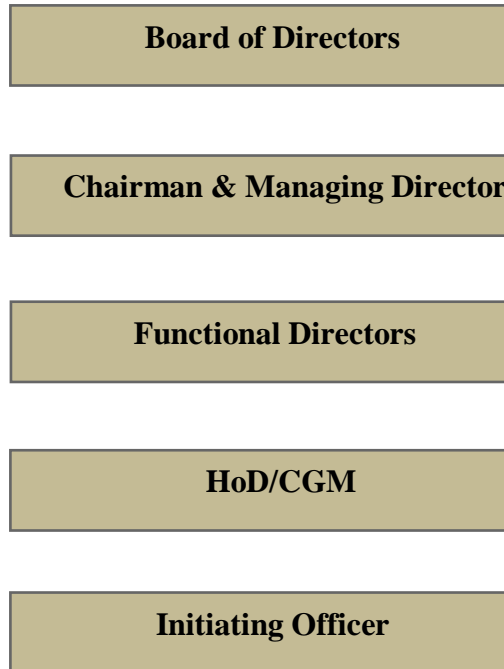

The overall management of the company rests with the Board of Directors of the company, the highest decision making body within the company. The Board of Directors is accountable to the shareholders of the company, which is the ultimate authority of a company.

The decisions are taken by the appropriate authorities as per the powers delegated under the Delegation of Powers. The disposal and channel of submission of different types of activity department wise is as per flow chart as per the departmental hierarchy as under:

INDIVIDUAL DEPARTMENTAL HIERARCHY

4 (1) (b) (iv) THE NORMS SET BY IT FOR THE DISCHARGE OF ITS FUNCTIONS

The Company discharges its functions in accordance with the directives of the Board of Directors, Presidential directives, Memorandum and Articles of Association of the Company, Guidelines issued by the Department of Public Enterprises, Directive and Guidelines issued by the Central Vigilance Commission, relevant Laws and Regulations and various Directives issued by the Ministry of Defence from time to time.

Officers and Supervisors are governed by the GSL Conduct, Discipline and Appeal (Amended) Rules 2019, and other service conditions as applicable and amended from time to time. The workers of GSL are governed by the GSL Certified Standing Orders and other service conditions as applicable and amended from time to time. In the event of employee grievance, the same is addressed through grievance redressal mechanism.

[Detail Grievance redressal mechanism for Officers, Supervisors and workmen](#)

GSL is a MoU signing company. The company signs a MoU with its Administrative Ministry every year on various parameters which are monitored for evaluation and GSL performance is graded.

[A copy of signed MoU for 2020-21 is attached.](#)

4 (1) (b) (v) THE RULES, REGULATIONS, INSTRUCTIONS, MANUALS AND RECORDS, HELD BY IT OR UNDER ITS CONTROL OR USED BY ITS EMPLOYEES FOR DISCHARGING ITS FUNCTIONS

Company Affairs:

- [Memorandum of Association Articles of Association](#)
- [Audit Committee Charter](#)

Finance & Accounts:

- [Accounting standards](#)
- [Accounting policies](#)

Human Resources:

- [Suggestion Scheme](#)
- [Officers & Supervisors Conduct, Disciplines and Appeal \(Amended\) Rules, 2019](#)
[Complaints committee for enquiring into complaints of sexual harassment](#)
[Medical scheme for executives](#)
- [Medical scheme for supervisors](#)
- [Goa Shipyard employees death benevolent fund](#)
- [Post Retirement Medical scheme for executives supervisors and workmen](#)
[Telecommunication policy for officers & supervisors](#)
- [Policy for financial assistance to employee hospitalised due to accident while on duty](#)
[PRPScheme for executives and supervisors](#)
- [TA/ DA rules for officers supervisors and workmen Service rules for officers and supervisors](#)
- [Promotion policy for supervisors](#)
- [Recruitment rules for supervisors](#)
- [Scheme for reimbursement of tuition fees for officers & supervisors](#)
- [GSL Executives and non unionised supervisors superannuation pension scheme](#)
[Foreign travel \(amendment\) rules 2017](#)
- [Recruitment And Promotion rules for officers](#)
- [Safety manual](#)
- [Whistle blower policy](#)
- [CSR policy 2021](#)
- [Certified standing orders](#)

- [Grievance redressal scheme for workmen](#)
- [Job Rotation Policy for Officers](#)
- [Grievance redressal scheme for supervisors and executives](#)
- [Policy procedure and rules for GSL employees proceeding abroad](#)
- [GSL corporate publicity policy2014](#)
- [Officers residential accommodation allotment rules](#)
- [Scheme for compassionate appointment](#)
- [Loans and advances for officers](#)
- [Loans and advances for supervisors](#)
- [Professional membership fee reimbursement scheme](#)
- [Recruitment And Career Development Plan And Allied Matters](#)
- Annexure I To V Of CDA Rules Applicable To Officers And Supervisors

4 (1) (b) (vi) A STATEMENT OF THE CATEGORIES OF DOCUMENTS THAT ARE HELD BY IT OR UNDER ITS CONTROL

Sr. No.	Subject	Document	Department
1	Incorporation	<ol style="list-style-type: none"> 1. Memorandum & Articles of Association 2. Statutory registers under the Companies Act, 2013 3. Annual Reports along with Annual Returns 4. Returns and Forms filed with the Registrar of Companies. 5. Municipal License 	CS & legal
2	General Meetings	<ol style="list-style-type: none"> 1. Notices/Agenda and Minutes Book of General Meetings of Shareholders. 2. Minutes of Board of Directors Meeting 	CS & legal
3	Accounts	<ol style="list-style-type: none"> 1. Books of Accounts in electronic form 2. Annual Statement of Financial Results 3. Annual Report 4. Documents pertaining to payment of Income Tax, Tax deducted at Sources etc. 5. Procurement/Purchase manual 6. Audit Reports 	Finance
4	Establishment Matters	Documents with respect to employees establishment matters	HR
5	CSR and Other Welfare Schemes	Policy on CSR & Welfare activities	HR

4 (1) (b) (vii) THE PARTICULARS OF ANY ARRANGEMENT THAT EXISTS FOR CONSULTATION WITH, OR REPRESENTATION BY, THE MEMBERS OF THE PUBLIC IN RELATION TO THE FORMULATION OF ITS POLICY OR IMPLEMENTATION

Various Parliamentary Committees go into issues relating to GSL's policies on specific areas like SC/ST/OBC Welfare measures, Official Language Implementation, etc. from time to time. The recommendations of Parliamentary Committees are taken into consideration for implementation.

1) (b) (viii) A STATEMENT OF THE BOARDS, COUNCILS, COMMITTEES AND OTHER BODIES CONSISTING OF TWO OR MORE PERSONS CONSTITUTED AS ITS PART OR FOR THE PURPOSE OF ITS ADVICE, AND AS TO WHETHER MEETINGS OF THOSE BOARDS, COUNCILS, COMMITTEES AND OTHER BODIES ARE OPEN TO THE PUBLIC, OR THE MINUTES OF SUCH MEETINGS ARE ACCESSIBLE FOR PUBLIC

Subject to applicable statutory provisions, the affairs of the company are managed and administered directly by a duly constituted Board of Directors and wherever necessary and desirable, by delegation. Apart from the Board level committees or other bodies required/contemplated under the law, for the smooth and efficient functioning of the Company, other committees, bodies etc. (illustratively, the Procurement Committee, Departmental Promotion Committee, Price Negotiation committee, etc) are formed/constituted from time to time by the company at various level(s), as its part, for the purpose of assisting and/or providing advice to the Board as also to the Officers at decision-making level, as the case may be, in arriving at informed decisions.

VARIOUS COMMITTEES OF BOARD OF DIRECTORS

- (a) Audit Committee of Directors
- (b) Procurement Sub Committee of Directors
- (c) Nomination & Remuneration Cum Human Resource Committee
- (d) Committee on Sustainable Development & Corporate Social Responsibility
- (e) Investment Committee
- (f) Project review Sub Committee (PRSC) of Board Of Directors
- (g) Share Transfer Committee

“Meetings of the Board of Directors and the Committees thereof are not open to the public and the minutes of such meetings are not accessible to public, being commercially confidential.”

[BOARD OF DIRECTORS OF GOA SHIPYARD LIMITED \(English\)](#)

[BOARD OF DIRECTORS OF GOA SHIPYARD LIMITED \(Hindi\)](#)

4 (1) (b) (ix) A DIRECTORY OF ITS OFFICERS AND EMPLOYEES:

NAME	DESIGNATION	OFFICE ADDRESS
Shri. Brajesh Kumar Upadhyay	Chairman & Managing Director	M/s Goa Shipyard Ltd. Vasco-da-gama, Goa - 403 802, Phone : 0832-2513943/2511388
Shri. Sunil Shivaling Bagi	Director (Finance)	M/s Goa Shipyard Ltd. Vasco-da-gama , Goa - 403802, Phone : 0832- 2513947
Shri.Capt. Jagmohan. (Retd)	Director(CPP&BD)	M/s Goa Shipyard Ltd. Vasco-da-gama , Goa - 403 802, Phone : 0832- 2500030
Mr. Sanjay Krishna Navhale	Chief Vigilance Officer	M/s Goa Shipyard Ltd. Vasco-da-gama, Goa - 403 802, Phone : 0832- 2500734
Shri. Clifford Pereira	Chief General Manager(Planning & PC)	M/s Goa Shipyard Ltd. Vasco-da-gama , Goa - 403 802 Phone: 0832-2513416
Shri. Sunil P. Yadav	GM(PROJECT FINANCE & ACCOUNTING)	M/s Goa Shipyard Ltd. Vasco-da-gama , Goa - 403 802, Phone : 0832- 2514196/2510063
Shri Anand B. Murshilli	GM(CORPORATE FINANCE)	M/s Goa Shipyard Ltd. Vasco-da-gama, Goa – 403 802 Phone: 0832-2518210.
Shri. Shashikant Shivaji Kamble	HOD (HR&A)	M/s Goa Shipyard Ltd. Vasco-da-gama , Goa – 403802Phone : 0832- 2510543
Shri Mr. Abhay V. Inge	HOD (FPG)	M/s Goa Shipyard Ltd. Vasco-da-gama , Goa - 403 802
Shri. Nagesh D. Pai	GM (SR)	M/s Goa Shipyard Ltd. Vasco-da-gama, Goa - 403 802 Phone : 0832-2514768

NAME	DESIGNATION	OFFICE ADDRESS
Shri. Cdr Saurabh Jain,(Retd.)	GM(P&PC)	M/s Goa Shipyard Ltd. Vasco-da-gama, Goa - 403 802 Phone : 0832-2513343
Shri. Dattaprasad Bhat	HOD (QA&R)	M/s Goa Shipyard Ltd. Vasco-da-gama, Goa - 403 802
Shri.M. Subramanian	GM(PP)	M/s Goa Shipyard Ltd. Vasco-da-gama, Goa - 403 802 Phone : 0832- 2501383
Shri. Vivek K. Sail	HOD(OS)	M/s Goa Shipyard Ltd. Vasco-da-gama, Goa - 403 802 Phone : 0832- 2514478
Shri.V.K. Deshpande	GM(GES)	M/s Goa Shipyard Ltd. Vasco-da-gama, Goa - 403 802
Shri Gaude Prakash Laxman	HOD(SMP)	M/s Goa Shipyard Ltd. Vasco-da-gama, Goa - 403 802 Phone : 0832- 2511572
Shri.P.Ravindran	General Manager(Production)	M/s Goa Shipyard Ltd. Vasco-da-gama, Goa - 403 802
Shri.Cmde Adikesh Vasudevan	GM(TS)	M/s Goa Shipyard Ltd. Vasco-da-gama , Goa - 403 802
Shri . Devanand S. Patekar	GM(Prod-CGP)	M/s Goa Shipyard Ltd. Vasco-da-gama, Goa - 403 802
Shri. S. P. Fernandes	AGM (Vigilance)	M/s Goa Shipyard Ltd. Vasco-da-gama , Goa - 403 802
Shri Kishor Manohar Samant	AGM (Legal)	M/s Goa Shipyard Ltd. Vasco-da-gama, Goa - 403 802 Phone: 0832-2500909
Shri. M. Kalaiyaran	AGM (Administration)	M/s Goa Shipyard Ltd. Vasco-da-gama, Goa - 403 802
Smt. Chhaya Jain	AGM (Company Secretary)	M/s Goa Shipyard Ltd. Vasco-da-gama, Goa - 403 802 Phone : 0832-2513870
Dr. Vedpal S. Tari	AGM (Medical)	M/s Goa Sipyard Ltd, Vasco-da-gama,Goa - 403 802
Shri. Vikas Chandra Ambastha	AGM(ERP-MCMV)	M/s Goa Sipyard Ltd, Vasco-da-gama,Goa - 403 802

Shri.Bindu Abraham	AGM(D/L)	M/s Goa Sipyard Ltd, Vasco-da-gama,Goa - 403 802
Shri.Nitendra G. Naik Adpaikar	AGM(Stores)	M/s Goa Shipyard Ltd. Vasco-da-gama, Goa - 403 802 Phone: 0832-2515627
Shri.Kiran Sukdo Salunke	AGM(P&PC)	M/s Goa Sipyard Ltd, Vasco-da-gama,Goa - 403 802
Shri. A.K. Gautam	AGM (OF/L)	M/s Goa Sipyard Ltd, Vasco-da-gama,Goa - 403 802
Shri.Cdr. Santosh Gupte	AGM(Prod.)	M/s Goa Sipyard Ltd, Vasco-da-gama,Goa - 403 802
Shri. Comdt (JG) Retd. R Panhotra	AGM (Delhi Office)	Goa Shipyard Limited, H Block Annexe, Defence Headquarters, Krishna Menon Marg, New Delhi- 110011, Phone: 011-23011249,Fax:011-2315681
Shri.J. Siva Ravi	AGM(NC)	M/s Goa Sipyard Ltd, Vasco-da-gama,Goa - 403 802
Shri. Ajit Kumar Singh	AGM(Civil)	M/s Goa Shipyard Ltd. Vasco-da-gama , Goa - 403 802 Phone: 0832-2515342
Shri.Dominic Cardoso	AGM(BAW)	M/s Goa Sipyard Ltd, Vasco-da-gama,Goa - 403 802
Shri. Yatin Hegde Desai	AGM(Chief Indigenization off)	M/s Goa Sipyard Ltd, Vasco-da-gama,Goa - 403 802
Shri. George P. Samuel	DGM (Comm)	C/o. Mazagon Dock Shipbuilders Ltd.,Dockyard Road, Mazagon, Mumbai- 400 010 Phone: 022- 23738321/23738749, Fax: 022-23738140
Shri. Abhishek Singh	DGM(EPSP)	M/s Goa Sipyard Ltd, Vasco-da-gama,Goa - 403 802
Shri.CDR. Maniyedath Harikrishnan (Retd.)	TA to CMD (DGM)	M/s Goa Shipyard Ltd. Vasco-da-gama, Goa - 403 802 Phone: 0832-2501310
Shri.Sanoj Kumar Pandey	DGM(IA)	M/s Goa Sipyard Ltd, Vasco-da-gama,Goa - 403 802
Shri. Rodrigues Fabian Savio	DGM(Pur)	M/s Goa Sipyard Ltd, Vasco-da-gama,Goa - 403 802

Shri.Jayesh Varma	DGM(HC)	M/s Goa Sipyard Ltd, Vasco-da-gama,Goa - 403 802
Shri.Prashant Kumar	DGM (SPS)	M/s Goa Sipyard Ltd, Vasco-da-gama,Goa - 403 802
Shri.Rupesh Kumtekar	DGM(Safety)	M/s Goa Sipyard Ltd, Vasco-da-gama,Goa - 403 802
Shri.Manoj Kumar Mishra	DGM(E&P)	M/s Goa Sipyard Ltd, Vasco-da-gama,Goa - 403 802
Shri. Mukesh K. Meena	DGM(Prod.)	M/s Goa Sipyard Ltd, Vasco-da-gama,Goa - 403 802
Shri. Purshottam Bhat	DGM(OS)	M/s Goa Sipyard Ltd, Vasco-da-gama,Goa - 403 802
Shri.Nikhil Wagh	Sr. Manager(Public Relations)	M/s Goa Shipyard Ltd. Vasco da gama, Goa - 403 802Phone : 0832-2517132
Shri. Amit Kumar	EA to CMD	M/s Goa Shipyard Ltd. Vasco-da-gama, Goa - 403 802 Phone : 0832-2513943/2511388
Shri Vibhu Singh Pratihar	Dy. Commandant(CISF)	M/s Goa Shipyard Ltd. Vasco-da-gama, Goa - 403 802 Phone: 0832-2514019

TELEPHONE DIRECTROY OF EXECUTIVES

4 (1) (b) (x) THE MONTHLY REMUNERATION RECEIVED BY EACH OF ITS OFFICERS AND EMPLOYEES, INCLUDING THE SYSTEM OF COMPENSATION AS PROVIDED IN ITS REGULATIONS

The remuneration of the Executives and Non-Unionized Supervisors of the Company is governed by the guidelines issued by the Department of Public Enterprises (DPE), Government of India. The pay scales are on Industrial DA (IDA) pattern.

The DPE guidelines on pay scales of Executives and Non-Unionised Supervisors are also available on DPE website www.dpe.gov.in

The pay scales of Executives and Non-Unionized Supervisors effective from 01.01.2017 are as under:

DESIGNATION	REVISED SCALES OF PAY (in Rs.)
BOARD LEVEL EXECUTIVES	
CMD (Sch-B)	180000-3%-320000
Director (Sch-B)	160000-3%-290000
BELOW BOARD LEVEL EXECUTIVES	
CGM (E-8)	120000-3%-280000
GM (E-7)	100000-3%-260000
AGM (E-6)	90000-3%-240000
DGM (E-5)	80000-3%-220000
SM (E-4)	70000-3%-200000
MGR (E-3)	60000-3%-180000
DM (E-2)	50000-3%-160000
AM (E-1)	40000-3%-140000
JM (E-0)	30000-3%-120000
NON – UNIONISED SUPERVISORS	
S-5	29000-3%-110000
S-4	27000-3%-100000
S-3	25000-3%-90000
S-2	23000-3%-80000
S-1	21000-3%-70000

The remuneration of unionized workmen is fixed by way of negotiations held between Management and Workers Union, subject to the overall guidelines in this regard which are promulgated by the Department of Public Enterprises, Government of India.

The pay scales of Workmen with effect from 01.01.2017 are as under:

DESIGNATION	REVISED SCALES OF PAY (in Rs.)
WORKMEN	
W-13	20800-3%-78500
W-12	20000-3%-75500
W-11	19200-3%-72500
W-10	18400-3%-69500
W-9	17600-3%-66500
W-8	16600-3%-63500
W-7	16100-3%-60500
W-6	15600-3%-57500
W-5	15100-3%-53000
W-4	14600-3%-48500
W-3	11400-3%-44000
W-2	10800-3%-39500
W-1	10100-3%-35000

In addition to the above, Dearness Allowance, House Rent Allowance, Perks & Allowances, Medical facilities, Provident Fund, Gratuity, Superannuation Benefits etc. are provided as applicable to the respective cadres in accordance to the Company's rules as applicable and amended from time to time.

4 (1) (b) (xi) THE BUDGET ALLOCATED TO EACH OF ITS AGENCY, INDICATING THE PARTICULARS OF ALL PLANS, PROPOSED EXPENDITURES AND REPORTS ON DISBURSEMENTS MADE

Nil

4 (1) (b) (xii) THE MANNER OF EXECUTION OF SUBSIDY PROGRAMMES,
INCLUDING THE AMOUNTS ALLOCATED AND THE DETAILS OF BENEFICIARIES
OF SUCH PROGRAMMES

Nil

4 (1) (b) (xiv) DETAILS IN RESPECT OF THE INFORMATION, AVAILABLE TO OR HELD BY IT, REDUCED IN AN ELECTRONIC FORM

Information relating to Company profile, Business, Financial performances, Share holding pattern, Annual Report is held by the company in electronic form and is available on the website of the Company – www.goashipyard.in

4 (1) (b) (xv) THE PARTICULARS OF FACILITIES AVAILABLE TO CITIZENS FOR OBTAINING INFORMATION, INCLUDING THE WORKING HOURS OF A LIBRARY OR READING ROOM, IF MAINTAINED FOR PUBLIC USE

GSL being a relatively small company the information can be arranged by CPIO in his office. Any person aggrieved can call from the GSL reception centre or meet CPIO in person to collect the information in accordance with the RTI Act 2005.

4 (1) (b) (xv) THE PARTICULARS OF FACILITIES AVAILABLE TO CITIZENS FOR OBTAINING INFORMATION, INCLUDING THE WORKING HOURS OF A LIBRARY OR READING ROOM, IF MAINTAINED FOR PUBLIC USE

GSL being a relatively small company the information can be arranged by CPIO in his office. Any person aggrieved can call from the GSL reception centre or meet CPIO in person to collect the information in accordance with the RTI Act 2005.

4 (1) (b) (xvi) THE NAMES, DESIGNATIONS AND OTHER PARTICULARS OF THE PUBLIC INFORMATION OFFICERS

Authority	Name & Designation	ContactNo.	E-mail id.
Transparency Officer	Shri. Mr. Clifford Pereira, CGM(Planning)	(0832) 2513416	cliffordpereira@goashipyard.com
First Appellate Authority	Shri. Shashikant Shivaji Kamble, HOD (HR&A)	(0832) 2510543	shashikantkamble@goashipyard.com
Central Public Information Officer	Shri. Prashant Vasant Gunjekar, SM (HR)	0832- 2512359 (Extn-4658)	prashantgunjekar@goashipyard.com
Assistant Public Information Officer	Ms. Vanda Fernandes, M (HR)	0832- 2515703	vandafernandes@goashipyard.com

**4 (1) (b) (xvii) SUCH OTHER INFORMATION AS MAY BE PRESCRIBED
AND THEREAFTER UPDATE THESE PUBLICATIONS EVERY YEAR**

I. Departmental Disciplinary Proceedings

Particulars	Executive	Non-Executive	Total
Number of cases of pending enquiries	0	05	05

II. Receipt & Disposal of RTI Applications

GSL has received 12 **RTI applications** starting from 01.01.2024 till 02.02.2024

III. RTI applications and appeals received and their responses (except relating to personal information) are uploaded on the website.

IV. RTI Manual / Handbook is prepared and is placed at the GSL reception counter for the convenience and information of the public at large, the same is amended from time to time.

V. Committee of APIO, PIOs and FAAs is set up to disclose frequently asked information (FAQ's, copy of memo, issued by competent authority)

VI. Tender- Notices/Enquiries and corrigenda there on:

Tendering in GSL is largely done through e-procurement portal. The details are available on the website www.eprocuregsl.nic.in the information on tenders can also be accessed through GSL website www.goashipyard.in in the tenders tab under GSL E-procurement.

FREQUENTLY ASKED QUESTIONS (FAQs) ON RTI ACT

Q.1: What is information under RTI Act?

Information is any material in any form. It includes records, documents, memos, e-mails, opinions, advices, press releases, circulars, orders, logbooks, contracts, reports, papers, samples, models, data material held in any electronic form. It also includes information relating to any private body which can be accessed by the public authority under any law for the time being in force.

Q.2: What is a Public Authority?

A "public authority" is any authority or body or institution of self government established or constituted by or under the Constitution; or by any other law made by the Parliament or a State Legislature; or by notification issued or order made by the appropriate Government. It also includes the bodies owned, controlled or substantially financed and non-Government organizations substantially financed directly or indirectly by funds provided by the appropriate Government.

Q.3: What is a Central Public Information Officer?

Public authority must designate some of its Officers as 'Central Public Information Officer (CPIO)' under section (5) of the RTI Act and the CPIO shall deal with the requests received from persons seeking information and render reasonable assistance to the persons seeking such information under purview of this Act.

Q.4: What does record mean under RTI Act?

Record under RTI Act includes:

- (a) any document, manuscript and file;
- (b) any microfilm, microfiche and facsimile copy of a document;
- (c) any reproduction of image or images embodied in such microfilm (whether enlarged or not); and
- (d) any other material produced by a computer or any other device;

Q.6: What is the Fee for the BPL applicant for Seeking Information?

If the applicant belongs to below poverty line (BPL) category, he/she is not required to pay any fee under this Act. However, the applicant should submit a proof in support of his/her claim to belong to the below poverty line as defined by appropriate Government.

Q.8: Is it required to give any reason for seeking information?

The information seeker is not required to give reasons for seeking information.

Q.9: Is there any provision for exemption from Disclosure of information?

Sub-section (1) of section (8) and section (9) of the Act enumerate the types of information which are exempted from disclosure. Sub-section (2) of section (8), however, provides that information exempted under sub-section (8) (1) or exempted under the Official Secrets Act, 1923 can be disclosed, if public interest in disclosure overweighs the harm to the protected interest.

Q.10: Is there any assistance available to the Applicant for filing RTI application?

If any person is unable to make a request in writing, they may seek the help of the Central Public Information Officer (CPIO) to write application and the Central Public Information Officer shall render reasonable assistance. Where a decision is taken to give access to a disabled person to any document, the CPIO shall provide such assistance to the person as may be appropriate for inspection.

Q.11: What is the Time Period for Supply of Information?

In normal course, the information to an applicant shall be supplied within 30 days from the receipt of their application by the public authority (Section 7 of RTI Act). If information sought concerns the life or liberty of a person, it shall be supplied within 48 hours. In case the application is sent through the Assistant Public Information Officer or it is sent to a wrong public authority, five days shall be added to the period of thirty days or 48 hours, as the case may be.

Q.12: Is there any provision of Appeal under the RTI Act?

If CPIO doesn't supply information within the prescribed time of 30 days or 48 hours, as the case may be, or the applicant is not satisfied with the information furnished, the applicant may prefer an appeal to the First Appellate Authority (FAA) who is Senior in rank to the Central Public Information Officer (CPIO). Such appeal should be filed within a period of 30 days from the date on which the limit of 30 days of supply of information is expired or from the date on which the information or decision of the Central Public Information Officer is received. The appellate authority of the public authority shall dispose of the appeal within a period of 30 days from the date of receiving such request or in exceptional cases within 45 days of the receipt of the appeal.

Q.13: Is there any scope for second appeal under the RTI Act?

If the First Appellate Authority fails to pass an order on the appeal within the prescribed period or if the appellant is not satisfied with the order of the First Appellate Authority, the applicant may prefer a second appeal with the Central Information Commission (CIC) within 90 days from the date on which the decision should have been made by the First Appellate Authority or was actually received by the appellant.

Q.14: Whether Complaints can be made under this Act? If yes, under what conditions?

If any person is unable to submit a request to a Central Public Information Officer either by reason that such an Officer has not been appointed by the concerned public authority; or the Assistant Public Information Officer has refused to accept his or her application or appeal for forwarding the same to the Central Public Information Officer or the Appellate Authority, as the case may be; or he has been refused access to any information requested under the RTI Act; or has not been given a response to a request for information within the time limit specified in the Act; or has been required to pay an amount of fee which the applicant considers unreasonable; or believes that he has been given incomplete, misleading or false information, the applicant can make a complaint to the Central Information Commission (CIC).

Q.15: What is Third Party Information?

Third party in relation to the Act means a person other than the citizen who has made request for the information. The definition of third party includes a public authority other than the public authority to whom the request has been made and shall be disposed/treated as per section (11) and other provisions of RTI Act.

Q.16: What is the Method of Seeking Information?

Any person who desires to obtain information under this Act should make an application to the Central Public Information Officer (CPIO) of the concerned public authority in writing in English or Hindi or in the official language of the area in which the application is made. The application should be precise and specific. The applicant should make appropriate payment of Rs.10/- as mentioned above as application fee under RTI Act at the time of submitting the application in the prescribed Form of that public authority if any.

Q.17: Will there be any additional payment for receiving information?

Fee chargeable for providing information u/s 7(1) is as under:

- (a) Rs. 2/- for each page created or copied (in A4 or A3 size paper).
- (b) Actual charge or cost price of a copy in larger size paper.

- (c) Actual cost or price for samples or models.
- (d) Rs. 5/- per hour for inspection of records. No fee for the first hour.

For providing information u/s 7(5) in printed or electronic format, the following fee has been prescribed:

- (a) Rs. 50/- per diskette or floppy.
- (b) Price fixed for the printed publication or Rs. 2/- per page of photocopy for extracts from the publication.

Q.19: What if CPIO receives other Public Authority RTI requests wrongly?

Under Section (6) (3) of the RTI Act, where an application is made to a public authority requesting for information:

- (i) which is held by another public authority; or
- (ii) The subject matter of which is more closely connected with the functions of another public authority; the public authority, to which such application is made, shall transfer the application or such part of it as may be appropriate to that other public authority and inform the applicant immediately about such transfer.

Further information may be seen at www.goashipyard.in

(Date of Last updation of RTI Portal- 02.02.2024)
